

Sandon - 1.75 Bowl (low divide sink)

White Glaze





abode

Product Basics:

	Product code	AW1048
	EAN 13 barcode	5060879995444
	Specification version	1 04/11/2025
	Finish	White Glaze
	Notes:	

note: model shown may not be displayed in the finish as described

Included parts:

 <p>2 x AX1002 (m) 90mm (1.5") Orbit manual basket strainer waste - long bolt</p>	 <p>1 x AX1105 (m) Rectangular overflow (55x30mm vertical)</p>	 <p>1 x AX1009-1 (m) 2 Bowl Pipework</p>	 <p>1 x AX4003 (m) Fitting & care instructions & data sheet - ceramic undermount</p>	

Recommended parts & accessories:

 <p>AX1011 Tap stabilising bracket</p>				
---	--	--	--	--

Packing summary:

- Packaging Type: Boxed
- Packaged size LxWxD: 840x540x275
- Gross weight (ea): 30.5Kg
- Net weight (ea): 25.25Kg

Warranty summary:

Details of warranty duration and terms & conditions for each product type can be found on our website: abodedesigns.co.uk/support/warranty

Certain products may benefit by registering the warranty here: abodedesigns.co.uk/support/register/warranty

Care summary:

- Clean the products regularly using soapy water and a non-abrasive cloth, regular cleaning will prevent the build-up of lime scale and dirt.
- Regular cleaning will prevent the build-up of lime scale and dirt.
- After cleaning rinse thoroughly with clean water to remove any cleaner residue.
- Avoid contact with any harsh chemical or abrasives, for more detail see supplied booklet or www.abodedesigns.co.uk

Mounting dimensions:

Type of Installation	Installation type recommended?	Recommended minimum base unit mm (20mm wall thickness)	Cut out size (length x width x corner radius mm)	Overall recessed fitting width mm (required for bowl(s), tap hole, overflow)	Minimum – Maximum worktop thickness (mm)	Additional fitting notes
Inset	Yes	800	765 x 435 R25			This sink must be fully supported
Undermount	Yes	1000	745 x 411 R15			To the outer of the top rad, We recommend that a cut out is made in timber and checked against the
Apron Front	No					
Flushmount	No					

Product drawing & dimensions:

Overall product size (mm): 795x465x220 corner radius 15

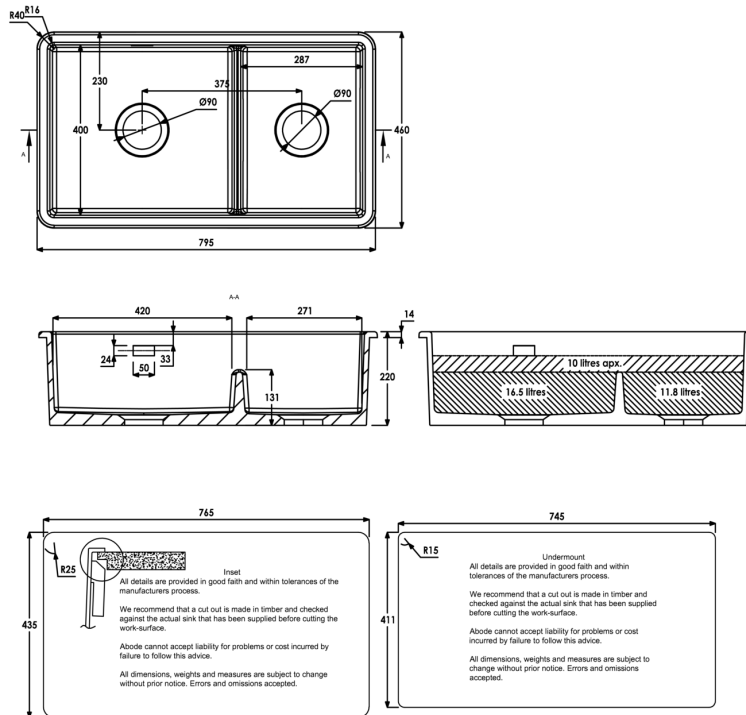

Attention notes:

We do not recommend use of instant hot water taps for this type of sink, repeated use may prematurely age the sink surface.

Great care is to be taken not to release the water directly on to the sink surface at full temperature.

The dimensions on ceramic fireclay products are subject to wider tolerances due to the nature of this natural material and the firing process.

***Important fabricator notes for Undermount, Apron Front & Flushmount sinks:**

The cut out size indicated is aligned with outside edge of the bowl top radius (similar to the example below):

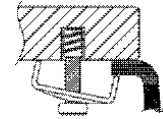

You should confirm with your client if the work surface cutout is to be cut flush, inside or outside this suggested perimeter shape & size.

If you create the cutout smaller or larger than the indicated size then the fit of the accessories may be affected and should be physically checked.

General:

All details are provided in good faith but do not include the tolerances of the material or manufacturing process.

We request that a test cutout is made in scrap timber and checked against the actual sink to be installed before committing to cutting the final work surface.

Abode can not accept liability for problems or costs incurred by failure to follow this request.

CAD cutout files can be downloaded from www.abodedesigns.co.uk

Bowl & drainer details:	Bowl 1 (typically main bowl):	Bowl 2: (typically ½ or ¾ or 2nd main bowl):	Bowl 3:	Drainer (left)	Drainer (right)
Bowl Size Width x Length x Depth x Radius (mm)	402 x 400 x 103 R10	287 x 400 x 103 R10	732 x 400 x 139 R10		
Bowl floor radius (mm)	10	10	10		
Wastehole diameter (mm)	90	90	90		
Overflow type	Rectangular		Rectangular		
Wall thickness (gauge mm)	12	12	12		
Bowl volume (apx. litres)	16.5	11.8	38.3		
Bowl texture / finish					



UK: Norcross Group (Holdings) Ltd. T/A Abode, Ladyfield House, SK9 1BU, UK. info@abodedesigns.co.uk
EU: ML, Unit 8 Purcellsinch Ind Est, Dublin Road, Kilkenny, R95 HP71, Ireland. euinfo@abode.eu

04/11/2025 - This sheet is a summary of the product information full details are available on request, errors & omissions excepted. © www.abodedesigns.co.uk